

Ball Stud Receivers Spring Catches

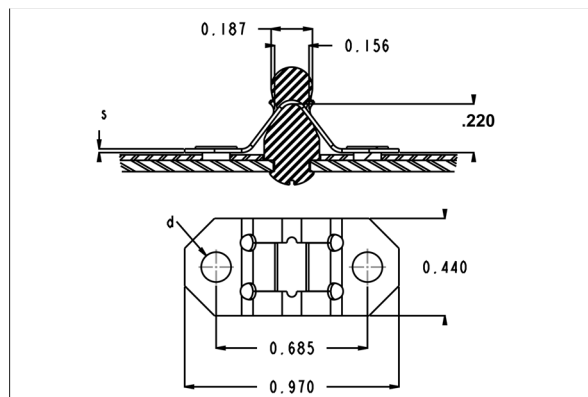

Metric

Part Number	Legacy Part Number	Pull Out Force on Ball Stud (lbs.)	Pull Out Force on Serrated Pin (lbs.)	Mounting Hole Diameter (d)	Material Thickness (s)
136582	C04893-012	3.50	5.00	0.105	0.012
136583	C04893-017	8.00	9.00	0.105	0.017
135307	C04893-028	18.00	24.00	0.105	0.028
136537	C01663-012	3.50	5.00	0.135	0.012
136538	C01663-017	8.00	9.00	0.135	0.017
136539	C01663-022	12.00	13.00	0.135	0.022
136540	C01663-028	18.00	24.00	0.135	0.028

Most parts manufactured in spring steel

APPLICATION INFORMATION

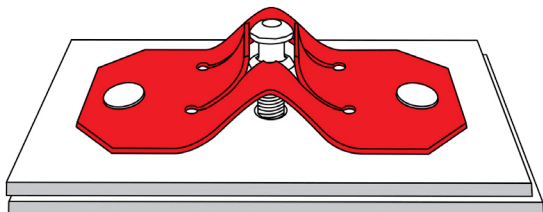

- Used to secure doors and other serviceable panels
- When latched, the spring legs of the clip continually bear inward on the stud, holding the latched unit snug against the panel
- Wear and tear is eliminated because there is no direct contact